

060-0200 Series
060-0250 Series

Travel Trailer Latch Dead Bolt Option

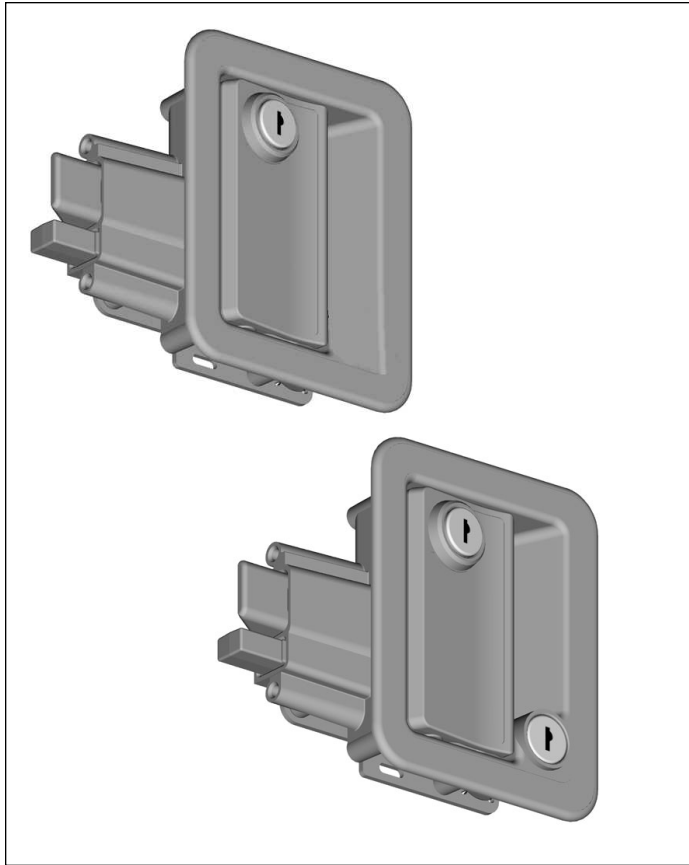

DESIGNED FOR:

- All doors with thickness of 1-1/4" to 1-1/2" (other door thicknesses available -- please inquire)
- Universal applications either right or left handed



www.trimarkcorp.com



500 Bailey Avenue
P.O. Box 350
New Hampton, Iowa 50659
Tel: 641-394-3188
Fax: 641-394-2392
1-800-447-0343
www.trimarkcorp.com

ISO 9001
United States



TriMark Europe

Cedar Court
Walker Road
Bardon Hill
Coalville LE67 1TU
United Kingdom
Tel: +44 (0)1530 512460
Fax: +44 (0)1530 512461
www.trimarkeu.com

ISO 9002
Europe



060-0200 Series Travel Trailer Latch 060-0250 Series Dead Bolt Option

THE UNIQUE SHAPE OF THIS DOOR LATCH IS A
TRADEMARK OF TRI/MARK CORPORATION

AVAILABLE:

- With optional built-in dead bolt (see next page)
- In locking or non-locking configurations
- Locking model features a 6-wafer lock plug with shuttered automotive keyway and is available keyed alike or keyed different. Master keying is standard
- With or without night lock

MATERIAL:

- Major components: SAE 903 die cast zinc alloy
- Strike plate (standard version): SAE 903 die cast zinc alloy
- Strike plate (optional dead bolt version): Steel

FINISH:

- Major components: Copper-nickel-chrome plated or color coordinated powder coating
- Strike plate (standard version): Black powder coating
- Strike plate (optional dead bolt version): Zinc plated

INSTALLATION:

- Six 8-32 UNC mounting screws (supplied separately)

060-0250 SERIES DEAD BOLT FEATURES:

- Built-in dead bolt eliminates the need for an add-on residential type dead bolt
- New inside lock knob assembly allows for easy operation
- Requires the same cut-out detail as the standard latch assembly
- Same fasteners may be used for all versions
- Dead bolt locks into the fully extended position for true dead bolt functioning
- Available with both key cylinders keyed alike which eliminates the need for separate keys
- Master keying is standard for paddle key cylinder

Individual part dimensions are for reference only. Refer to individual part drawings for complete dimensions, specifications, and installation procedures. Engineering assistance and application drawings are available.

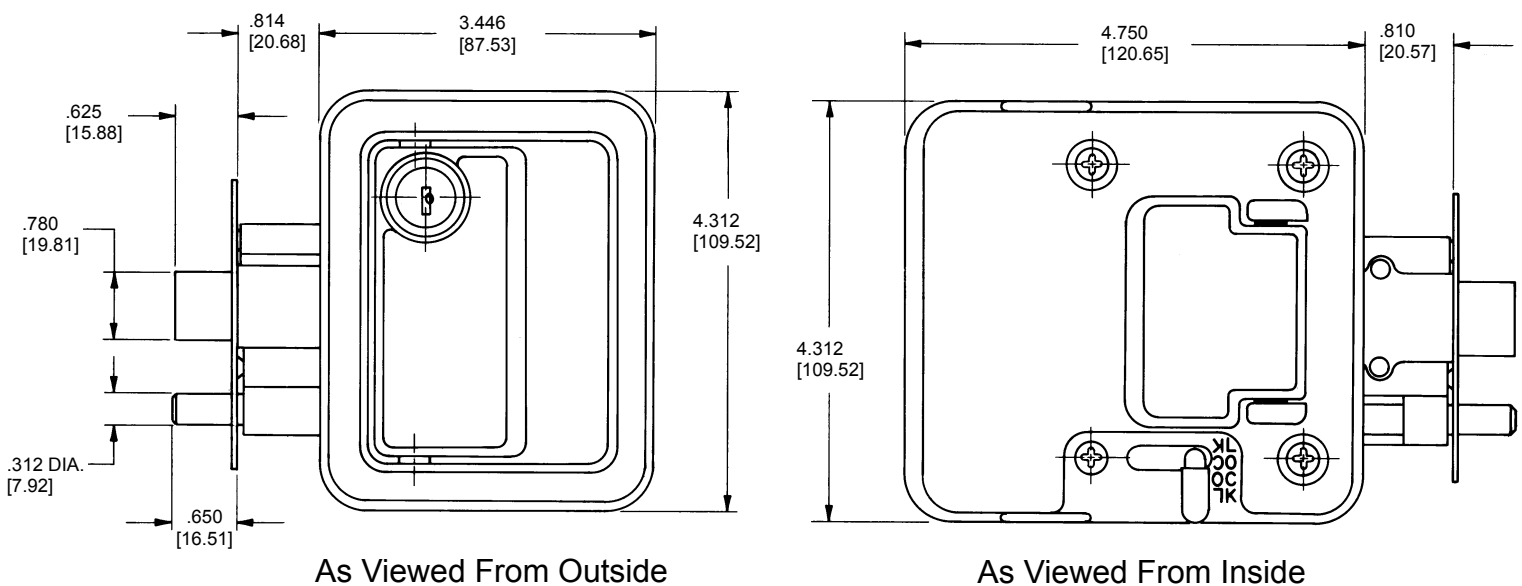

METRIC DIMENSIONS
SHOWN IN BRACKETS

Locking Model With Night Lock

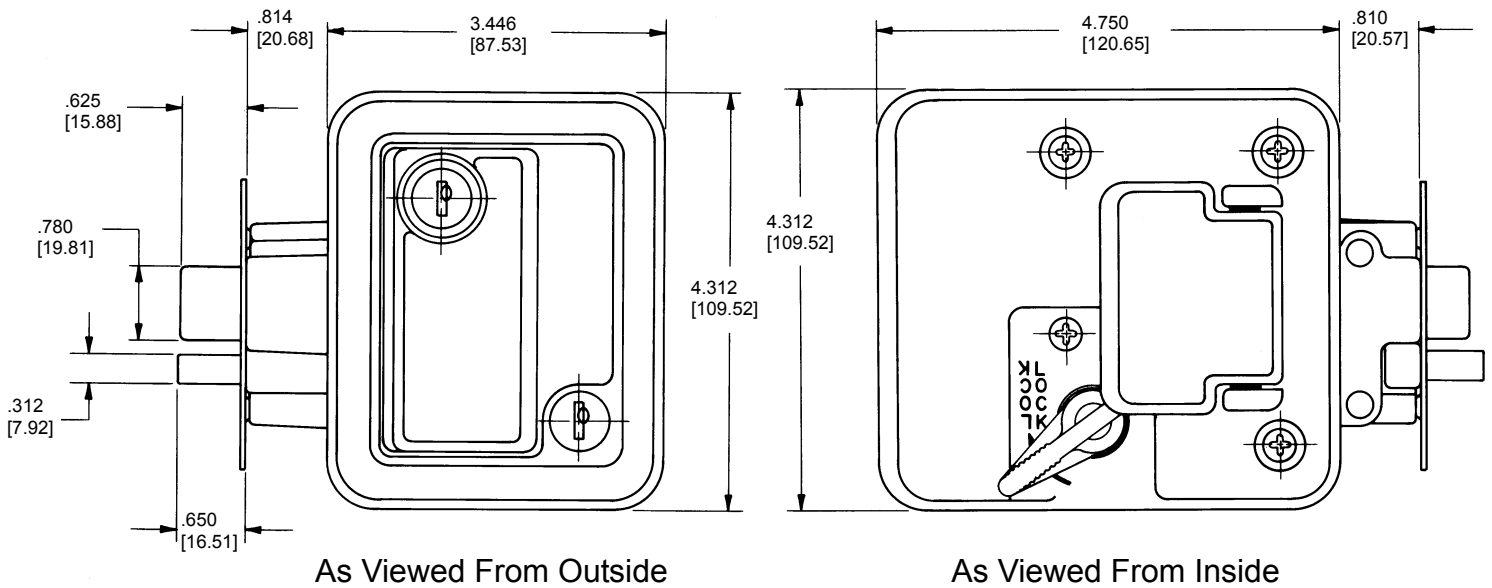

Built-In Dead Bolt Option

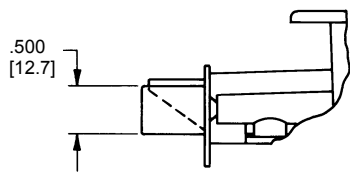

Suggested Door Cut-Out For Latch

Suggested Door Edge Cut-Out For Use With Door Edge Cover (Standard or Dead Bolt Version)

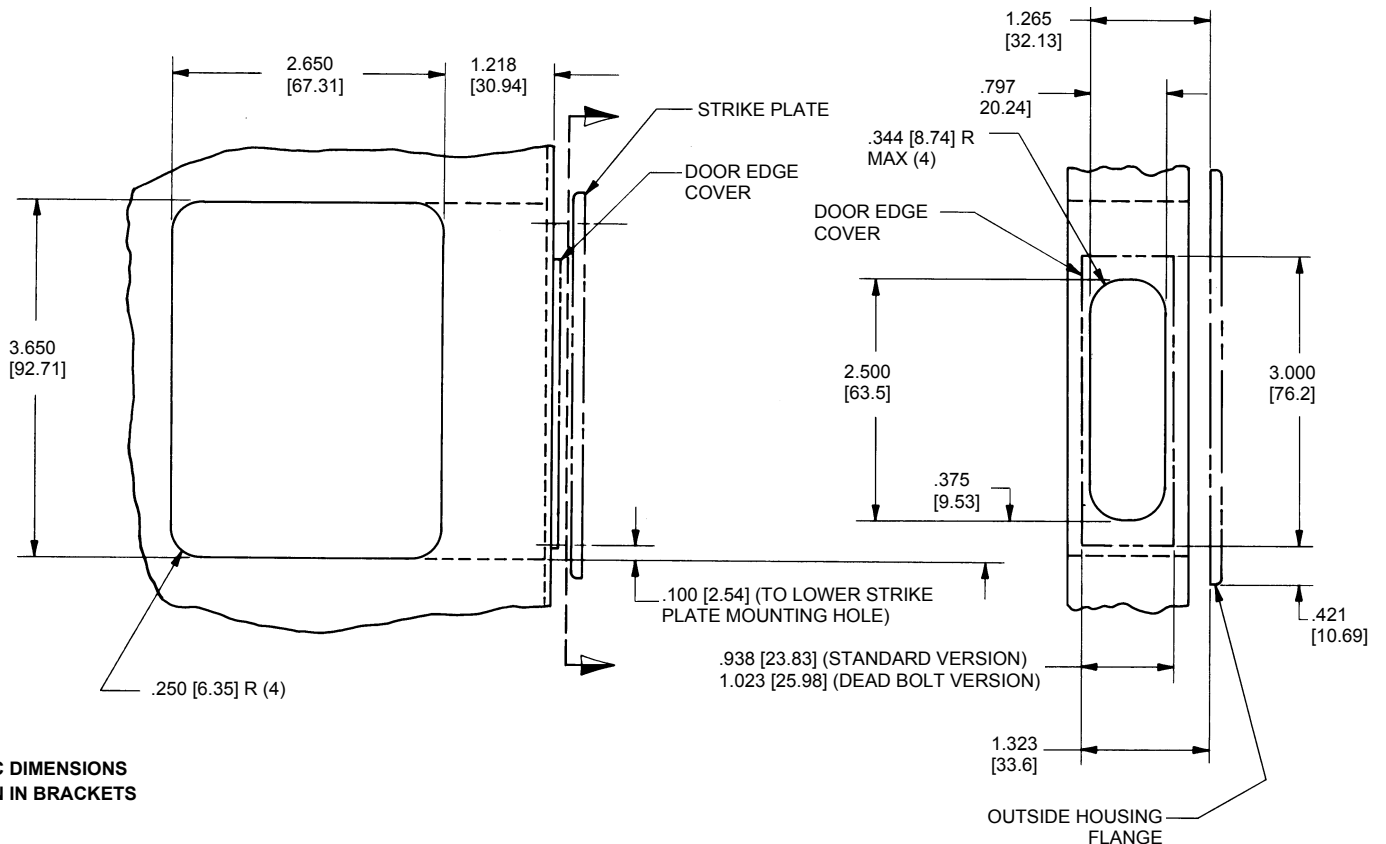

METRIC DIMENSIONS SHOWN IN BRACKETS

100-0500 Series Strike Plate

(Dimensions Shown for Either Standard or Dead Bolt Version)

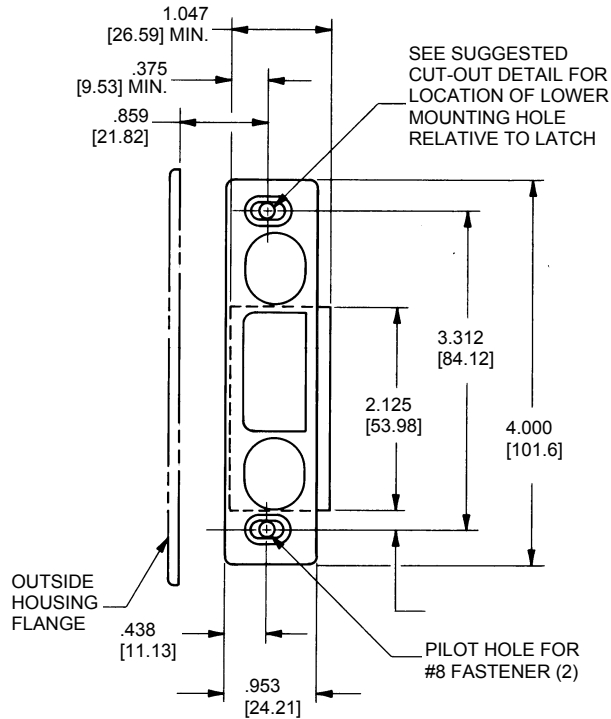

Die Cast Strike Plate
For Standard Version

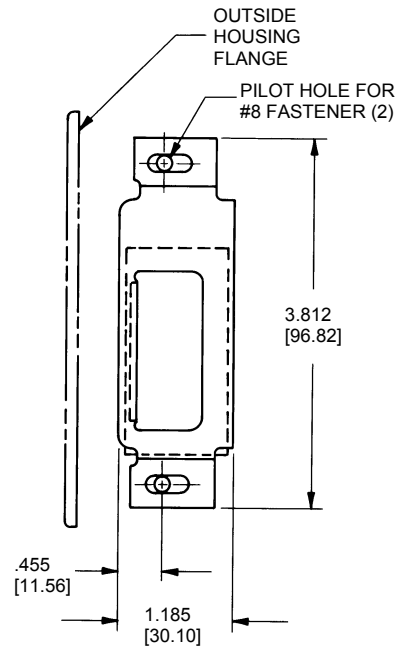

Stamped Steel Strike Plate
For Dead Bolt Version

